

Issue Date: 10-14-2009
Revision Date: 11-16-2023
Renewal Date: 10-31-2024

DIVISION: 06 00 00 – WOOD, PLASTICS AND COMPOSITES
Section: 06 63 00 - Plastic Railings

REPORT HOLDER:

Eastern Wholesale Fence LLC
274 Middle Island Road
Medford, NY 11763
(800) 339-3362
www.easternfence.com
www.illusionsvinylrailing.com

ADDITIONAL LISTEES:

Southern Vinyl Manufacturing LLC
2010 Smithfield Way
Kinston, NC 28504
(252) 523-2520
www.svmlc.com

Vinyl By Design, Inc.
67002 IN-15
New Paris, IN 46553
(574) 378-7117
www.vbdinc.com

REPORT SUBJECT:

Illusions™ Vinyl Railing System

1.0 SCOPE OF EVALUATION

1.1 This Research Report addresses compliance with the following Codes:

- 2021, 2018, 2015 *International Building Code*® (IBC)
- 2021, 2018, 2015 *International Residential Code*® (IRC)

NOTE: This report references the most recent Code editions noted. Section numbers in earlier editions may differ.

1.2 The *Illusions™ Vinyl Railing System* has been evaluated for the following properties:

- Structural performance
- Durability
- Surface Burning

1.3 The *Illusions™ Vinyl Railing System* has been evaluated for the following uses:

- The *Illusions™ Vinyl Railing System* is a guard or guardrail under the definitions of the referenced codes. It is intended for use at or near the open sides of elevated walking areas of buildings and walkways as required by the codes.
- Guard systems recognized in this report may be used in One- and Two-Family Dwellings regulated by the IRC and all construction types regulated by the IBC in accordance with IBC Section 705.2.2 and 705.2.3.1, Exception 2 and 3. Guards less than 42 inches high are limited to use in One- and Two-Family Dwellings (IRC). See Tables 1 and 2 for additional restrictions based upon Use and Occupancy Classification.

2.0 STATEMENT OF COMPLIANCE

The *Illusions™ Vinyl Railing System* complies with the Codes listed in Section 1.1, for the properties stated in Section 1.2 and uses stated in Section 1.3, when installed as described in this report, including the Conditions of Use stated in Section 6.0.

3.0 DESCRIPTION

3.1 Guards are provided as level guards for level walking areas such as decks, balconies and porches and sloped guards for open sides of stairways.

3.1.1 Level guards are provided with rail lengths up to 120 inches in length (measured between the inside of support posts) and an installed height of up to 42 inches. See Tables 1 and 2.



3.1.2 Stair guards are provided with rail lengths up to 87.5 inches measured along the sloping length between the inside of supports and an installed height of up to 42 inches at the leading edge of the stair tread or landing. See Tables 1 and 2.

3.2 The *Illusions™ Vinyl Railing System* is an assemblage of extruded and molded components utilizing Poly Vinyl Chloride (PVC) material and aluminum reinforcements. The PVC components are produced in three colors: White, Beige, and Gray.

3.3 The guard system includes a top rail with an aluminum reinforcing insert, a bottom rail, vertical balusters, non-structural 4 inch by 4-inch post sleeves, rail to post brackets, a support block, decorative moldings, and post caps.

3.3.1 The top rail is a co-extruded PVC rail with either a “T” profile with overall sectional dimensions of 3.5 inches wide by 3.5 inches tall or a rectangular profile with overall sectional dimensions of 2 inches wide by 3.5 inches tall. Both top rails incorporate an extruded aluminum reinforcing insert. See Figures 1, 2, and 3.

3.3.2 The bottom rail is a co-extruded PVC rail with an overall sectional dimension of 2 inches wide by 3.5 inches tall. See Figure 3.

3.3.3 Balusters are provided in two styles: Traditional and Colonial.

3.3.3.1 Traditional balusters are co-extruded PVC with a 1.5 inches square sectional hollow profile.

3.3.3.2 Colonial balusters are a thermoformed PVC spindle with a 1.5 inches square-ended sectional hollow profile.

3.3.3.3 The balusters are secured to the top and bottom rail via insertion into the routed openings of the top and bottom rails.

3.3.3.4 The baluster spacing resulting from assemblies recognized in this report shall provide spacing such that a 4-inch diameter sphere cannot pass through any opening between balusters.

3.3.4 Top and bottom rails are attached directly to structural supports with plastic mounting brackets. See Figures 5 and 6.

3.3.5 Structural supports may be conventional wood framing or a Steel Post Mount. See Figure 7. A 4-inch by 4-inch co-extruded PVC post sleeve is utilized with the Steel Post Mount support and may also be used to sleeve a conventional 4x4 wood post. See Figure 4.

3.3.6 Steel Post Mounts are comprised of a 2-inch square steel tube and welded 5/8-inch-thick steel base plate for anchorage. A molded PVC spacer/mounting block provides for attachment of rail brackets. See Figure 7.

3.3.7 A support block is installed between the lower rail and the deck surface midway between supports.

4.0 PERFORMANCE CHARACTERISTICS

4.1 The guard systems described in this report has demonstrated the capacity to resist the design loadings specified in Chapter 16 of the IBC and Section R301 of the IRC when tested in accordance with ICC-ES AC174.

4.2 Structural performance has been demonstrated for a temperature range from -20°F to 125°F.

4.3 Materials used are deemed equivalent to preservative treated or naturally durable wood for resistance to weathering effects, decay, and attack from termites.

4.4 The PVC material used in the guard system has a flame spread index not exceeding 200 when tested in accordance with ASTM E84.

5.0 INSTALLATION

5.1 The *Illusions™ Vinyl Railing System* must be installed in accordance with the manufacturer’s published installation instructions, the applicable Code, and this Research Report. A copy of the manufacturer’s instructions must be available on the jobsite during installation.

5.2 The baluster connections to the top and bottom rails are made by inserting the balusters into the routed openings in both rails.



5.3 The top and bottom rails are attached directly to structural supports utilizing plastic mounting brackets. See Figures 5 and 6.

5.4 The top and bottom rails may be attached to either conventional wood supports or a 4-inch-square PVC post sleeve and Steel Post Mount. Conventional wood supports, including wood posts, are outside the scope of this report.

5.5 4x4 conventional wood posts may be covered by a 4-inch by 4-inch non-structural PVC post sleeve with decorative caps and moldings.

5.6 The wood in the supporting structure, including conventional posts, shall have a specific gravity of 0.50 (southern yellow pine) or greater.

5.7 The Steel Post Mount is attached to the supporting structure using four 3/8-inch anchoring bolts with flat washers. See Figure 7. The type and length of anchor bolts is dependent upon the material and condition of the supporting structure and is not within the scope of this report.

6.0 CONDITIONS OF USE

The guard assemblies identified in this report are deemed to comply with the intent of the provisions of the referenced building codes subject to the following conditions:

6.1 Installation must comply with this Research Report, the manufacturer's published installation instructions, and the applicable Code. In the event of a conflict, this report governs.

6.2 Conventional wood supports for guards are not within the scope of this report and are subject to evaluation and approval by the building official. Supports must satisfy the design load requirements specified in Chapter 16 of the IBC and must provide suitable material for anchorage of the rail brackets. Where required by the building official, engineering calculations and details shall be provided.

6.3 Anchorage of the Steel Post Mount assemblies are not within the scope of this report and are subject to evaluation and approval by the building official. Anchors must satisfy the design load requirements specified in Chapter 16 of the

building code and must meet the following minimum requirements:

6.3.1 A minimum of four anchor bolts must be used and located in the four pre-drilled holes in the post base plate.

6.3.2 The anchors must have a minimum nominal diameter equal to 3/8 inch.

6.3.3 When the supporting structure is a wood-framed deck, installation must include anchorage to suitable structural framing. Decking is not considered structural framing, and anchorage to decking alone is not an approved installation method.

6.3.4 Where required by the building official, engineering calculations and details shall be provided. The calculations shall verify that the anchorage complies with the building code for the type and condition of the supporting construction.

6.4 Compatibility of fasteners and other metallic components with the supporting structure, including chemically treated wood, is not within the scope of this report.

6.5 *Illusions™ Vinyl Railing System* is manufactured under a quality control program with inspections by Intertek Testing Services NA, Inc.

7.0 SUPPORTING EVIDENCE

7.1 Drawings and installation instructions submitted by the manufacturer.

7.2 The reports of testing and engineering analysis demonstrating compliance with the performance requirements of ICC-ES AC174, *Acceptance Criteria for Deck Board Span Ratings and Guardrail Systems (Guards and Handrails)*, revised December 2019 and ASTM D7032-17, *Standard Specification for Establishing Performance Ratings for Wood-Plastic Composite and Plastic Lumber Deck Boards, Stair Treads, Guards, and Handrails*.

7.3 Documentation of an Intertek approved quality control system for the manufacturing of products recognized in this report.





8.0 IDENTIFICATION

The *Illusions™ Vinyl Railing System* is identified with the manufacturer’s name, address, and telephone number; the product name; the maximum span between posts; and for applicable rails the statement “For Use in One-and Two-Family Dwellings Only;” the Intertek Mark as shown below; and the Code Compliance Research Report number (CCRR-0143).



9.0 OTHER CODES

This section is not applicable.

10.0 CODE COMPLIANCE RESEARCH REPORT USE

10.1 Approval of building products and/or materials can only be granted by a building official having legal authority in the specific jurisdiction where approval is sought.

10.2 Code Compliance Research Reports shall not be used in any manner that implies an endorsement of the product by Intertek.

10.3 Reference to the <https://bpdirectory.intertek.com> is recommended to ascertain the current version and status of this report

This Code Compliance Research Report (“Report”) is for the exclusive use of Intertek’s Client and is provided pursuant to the agreement between Intertek and its Client. Intertek’s responsibility and liability are limited to the terms and conditions of the agreement. Intertek assumes no liability to any party, other than to the Client in accordance with the agreement, for any loss, expense or damage occasioned by the use of this Report. Only the Client is authorized to permit copying or distribution of this Report and then only in its entirety, and the Client shall not use the Report in a misleading manner. Client further agrees and understands that reliance upon the Report is limited to the representations made therein. The Report is not an endorsement or recommendation for use of the subject and/or product described herein. This Report is not the Intertek Listing Report covering the subject product and utilized for Intertek Certification and this Report does not represent authorization for the use of any Intertek certification marks. Any use of the Intertek name or one of its marks for the sale or advertisement of the tested material, product or service must first be approved in writing by Intertek.





TABLE 1 – RECTANGULAR RAIL GUARD SPANS AND CODE OCCUPANCY CLASSIFICATIONS

Type	Maximum Dimensions ⁽⁴⁾	Baluster Style	Post	Connection Fastening Schedule			Code Occupancy Classification
				Top and Bottom Rail Bracket to Post	Top Rail Bracket to Rail	Bottom Rail Bracket to Rail	
Level ⁽¹⁾	96 in. by 42 in.	Colonial or Traditional	PVC-Sleeved Steel Post Mount	Four #10 x 1" self-tapping, pan head screws	Two #10 x 3/4" self-tapping pan head screws	Two #10 x 3/4" self-tapping, pan head screws	IBC / All Use Group Classifications ⁽³⁾ ⁽⁴⁾ and IRC
			PVC-Sleeved Wood Post	Four #10 x 1-1/2" self-tapping, pan head screws			
Stair ⁽²⁾	87.5 in. by 42 in.	Colonial or Traditional	PVC-Sleeved Steel Post Mount	Four #10 x 1" self-tapping, pan head screws	Two #10 x 3/4" self-tapping pan head screws	Two #10 x 3/4" self-tapping, pan head screws	
			PVC-Sleeved Wood Post	Four #10 x 1-1/2" self-tapping, pan head screws			
Level ⁽¹⁾	120 in. by 42 in.	Colonial or Traditional	PVC-Sleeved Steel Post Mount	Four #10 x 1" self-tapping, pan head screws	Two #10 x 3/4" self-tapping pan head screws	Two #10 x 3/4" self-tapping, pan head screws	IRC / One- and Two-Family Dwellings
			PVC-Sleeved Wood Post	Four #10 x 1-1/2" self-tapping, pan head screws			

⁽¹⁾ Length is clear space between supports.

⁽²⁾ Length is sloping distance of rail between supports.

⁽³⁾ See section 1.3 for IBC conditions of use.

⁽⁴⁾ Guards less than 42 inches high are limited to use in One- and Two-Family Dwellings (IRC).





TABLE 2 – T-RAIL GUARD SPANS AND CODE OCCUPANCY CLASSIFICATIONS

Type	Maximum Dimensions ⁽⁴⁾	Baluster Style	Post	Connection Fastening Schedule				Code Occupancy Classification
				Bracket	Top and Bottom Rail Bracket to Post	Top Rail Bracket to Rail	Bottom Rail Bracket to Rail	
Level ⁽¹⁾	120 in. by 42 in	Traditional	PVC-Sleeved Steel Post Mount	Nylon	Four #10 x 1" self-tapping, pan head screws	Four #10 x 3/4" self-tapping pan head screws	Two #10 x 3/4" self-tapping, pan head screws	IBC / All Use Group Classifications ⁽³⁾ ⁽⁴⁾ and IRC
			PVC-Sleeved Wood Post	Nylon	Four #10 x 1-1/2" self-tapping, pan head screws	Six #10 x 3/4" self-tapping pan head screws		
Level ⁽¹⁾	95.5 in. by 42 in	Colonial or Traditional	PVC-Sleeved Steel Post Mount	Molded PVC	Four #10 x 1" self-tapping, pan head screws	Four #10 x 3/4" self-tapping pan head screws	Two #10 x 3/4" self-tapping, pan head screws	
			PVC-Sleeved Wood Post	Molded PVC	Four #10 x 1-1/2" self-tapping, pan head screws	Six #10 x 3/4" self-tapping pan head screws		
Stair ⁽²⁾	87.5 in by 42 in	Colonial or Traditional	PVC-Sleeved Steel Post Mount	Molded PVC or Nylon	Four #10 x 1" self-tapping, pan head screws	Two #10 x 3/4" self-tapping pan head screws	Two #10 x 3/4" self-tapping, pan head screws	
			PVC-Sleeved Wood Post	Molded PVC or Nylon	Four #10 x 1-1/2" self-tapping, pan head screws			
Level ⁽¹⁾	120 in. by 42 in	Colonial or Traditional	PVC-Sleeved Steel Post Mount	Nylon	Four #10 x 1" self-tapping, pan head screws	Two #10 x 3/4" self-tapping pan head screws	Two #10 x 3/4" self-tapping, pan head screws	
			PVC-Sleeved Wood Post	Nylon	Four #10 x 1-1/2" self-tapping, pan head screws			

⁽¹⁾ Length is clear space between supports.

⁽²⁾ Length is sloping distance of rail between supports.

⁽³⁾ See section 1.3 for IBC conditions of use.

⁽⁴⁾ Guards less than 42 inches high are limited to use in One- and Two-Family Dwellings (IRC).



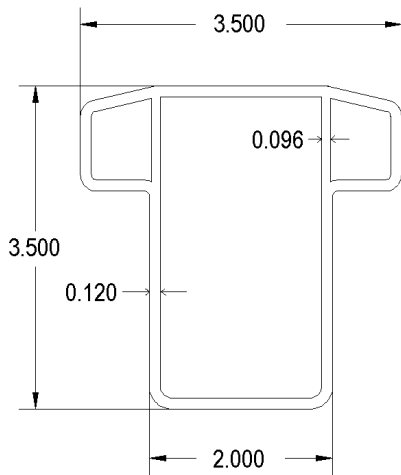

FIGURE 1
T-RAIL SYSTEM TOP RAIL PROFILE

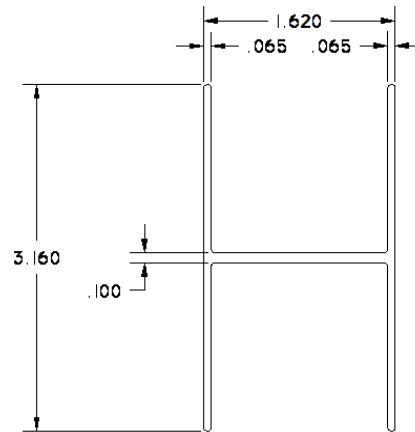

FIGURE 2
TOP RAIL INSERT

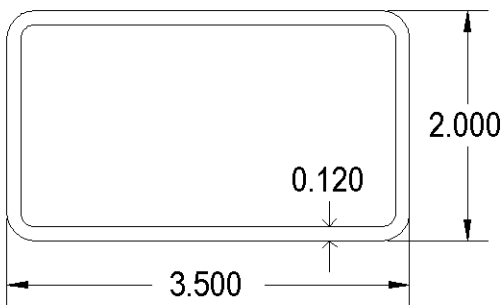

FIGURE 3
RECTANGULAR SYSTEM TOP AND BOTTOM RAIL
T-RAIL SYSTEM BOTTOM RAIL PROFILE

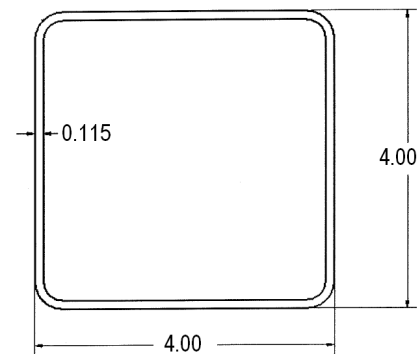

FIGURE 4
PVC POST SLEEVE

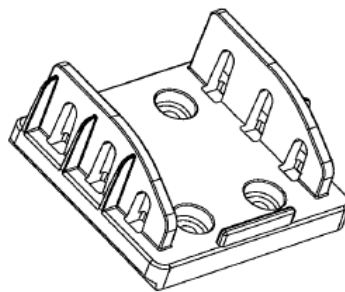
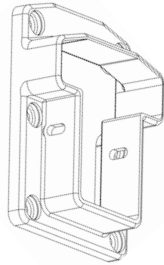
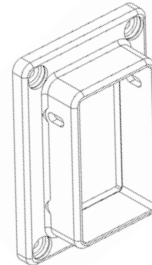

FIGURE 5
RECTANGULAR RAIL TOP AND BOTTOM RAIL BRACKET



LEVEL – PVC TOP RAIL BRACKET



LEVEL – PVC BOTTOM RAIL BRACKET

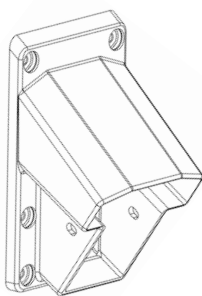

STAIR – PVC TOP RAIL BRACKET

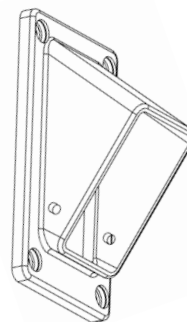
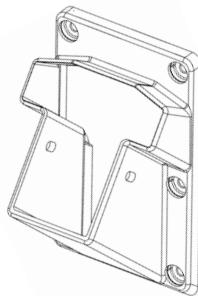

STAIR – PVC BOTTOM RAIL BRACKET

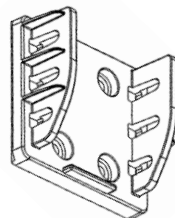
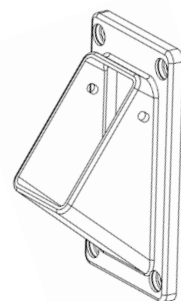

LEVEL & STAIR – NYLON TOP & BOTTOM RAIL BRACKET

**FIGURE 6
T-RAIL RAIL BRACKETS**

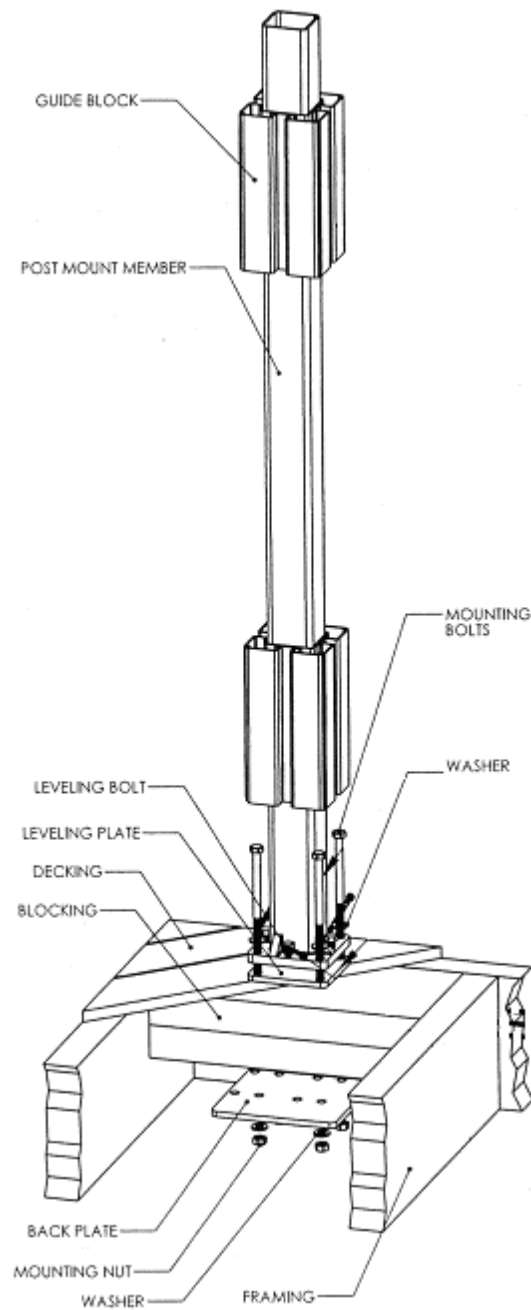

FIGURE 7
STEEL POST MOUNT

Note: Supporting structure (wood deck) is not within the scope of this report and must be designed and constructed in accordance with Chapter 16 of the IBC.