

## Tools and Materials Needed

### TOOLS

- Hacksaw or metal cutting saw
- Drill
- 5/32" Drillbit
- Screwdrivers
- Measuring Tape

### MATERIALS

- Post Kits
  - Panel Kits
  - Bracket Kits
- \* Fasteners are included with each component

## Straight Railing Installation

### Step 1 Measure and locate all posts

**1-1** Measure and locate all posts

**1-2** Choose the appropriate fasteners to fasten posts according to local building code. Ensure the posts are plumb. Use provided shims to adjust vertically. The internal spacing between posts is 72" or 96" if full sections are used.

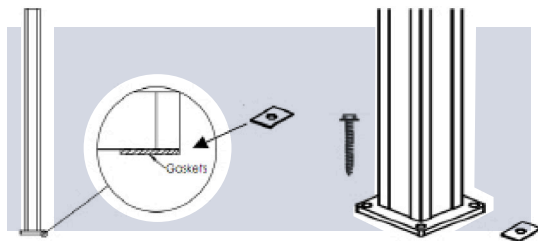

**Note:**

Pre-drill screw holes when installing brackets. Use supplied #10-1" pan head screws for bottom bracket

### Step 2 Install bottom rail and bottom brackets.

**2-1** Install rail support if required by building code.

**2-2** Locate and install one side of the bottom bracket 2 3/4" from the ground.

**2-3** Insert one side of the bottom rail into the installed bottom bracket, insert the other side of the rail into the second bracket. Then position the bottom rail between posts and secure the second bracket to the post with #10 1" screws, maintaining 2.

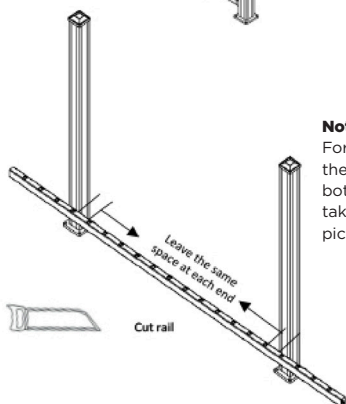
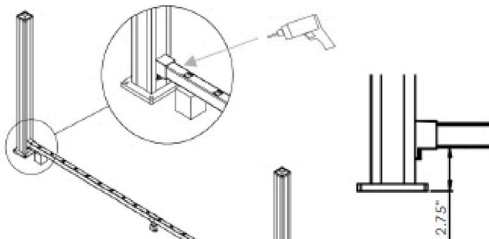

**Note:**

For shorter sections, cut the top rail to fit between the posts minus 5/8" for the bracket depth. For the bottom rail, subtract 5/16" from each end after taking an overall measurement to ensure equal picket spacing.

### Step 3 Install top rail and top brackets.

**3-1** Position the top brackets measuring from the top of the bottom bracket to the bottom of the top bracket using the measurements below

**3-2** Screw top brackets into post using (3) #10-1" pan head self drilling screws

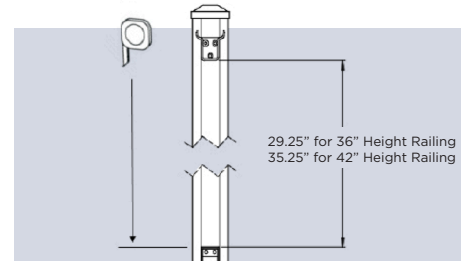

**3-3** Insert the bracket cover into the ends of rail.

**3-4** Set the top rail into the top bracket. Insert the bracket cover into the rail. Screw top brackets to rail using (2) #8-3/4" pan head self-drilling screws.

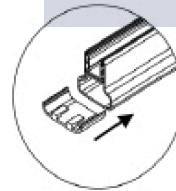

**3-4** Set the top rail into the top bracket. Screw top brackets to rail using (2) #8-3/4" pan head self-drilling screws.

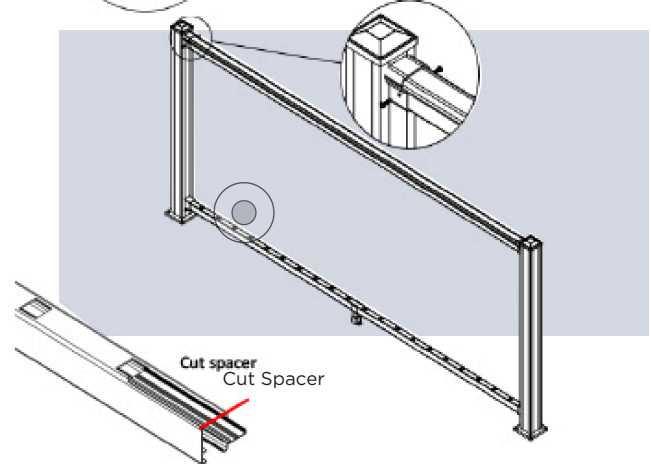

### Step 4 Install bottom rail and bottom brackets.

**Note** The size of the spacer for each rail end is different. (Special round labels will be used to identify the end spacer.)

Cut end spacers to fit the rails if necessary. To ensure equal picket spacing at each post, cut first and last spacers to equal lengths.

**4-1** Starting from either post but skipping the first spacer, insert pickets into top and bottom rail and snap in spacers one by one as shown below.

**Do not snap in spacers for the last 4 pickets. Insert last 4 pickets as a group and adjust the picket distance, then snap in the spacers**

**4-2** Make sure that all pickets are plumb, install end spacers, pickets into top and bottom rail and snap in spacers one by one as shown below.

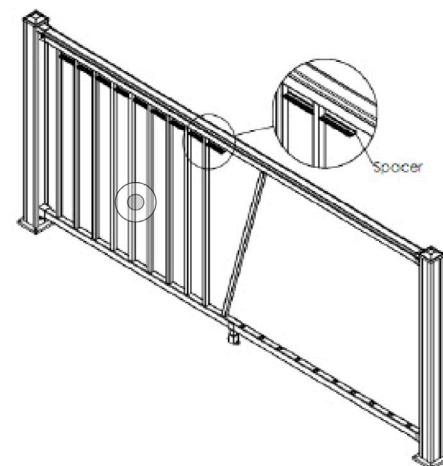

# Stair Railing Installation

## Step 1 Locate and install stair rail poststand install bracket base.

- 1.1 Measure and locate all posts.
- 1.2 choose the appropriate fasteners to fasten the post according to local building code.
- 1.3 use max. 1" thick wood board to position bottom stair bracket base. Secure bracket base to post using (2) #10 1" pan head self-drilling screws.
- 1.4 position the top rackets measuring from the top of the bottom bracket to the bottom of the top racket using the measurements below.

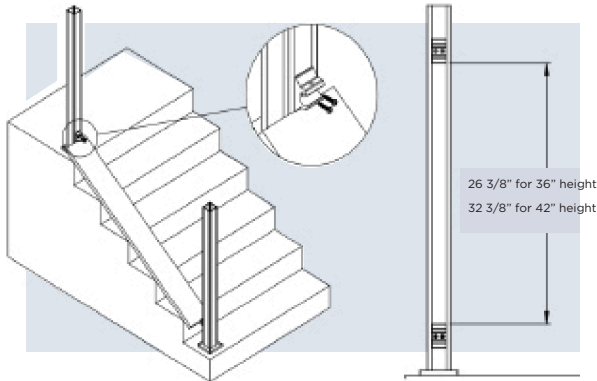

## Step 2 Cut and install top and bottom rail.

- 2.1 insert rail into lower bracket and mark rail to the edge of upper bracket. Add 1-1/8" to measurement and make cut. When cutting the bottom rail, make sure to leave the same amount of space at each end to ensure equal picket spacing.

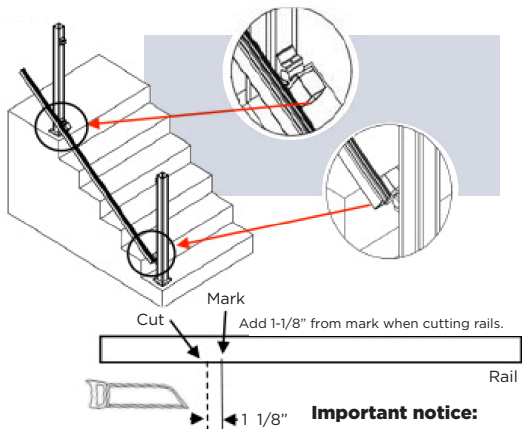

**Important notice:**  
When installing bottom rail of a stair railing section, remove the vinyl insert, and install in opposite direction as shown:

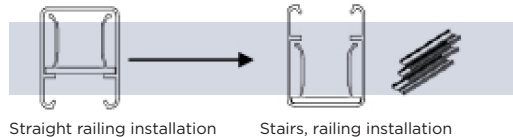

- 2.2 insert top rail into top stair bracket and slide into base bracket slot. Align the top bracket and base, then screw the top racket to base using (1) #8-3/4" pan head self-drilling screws.

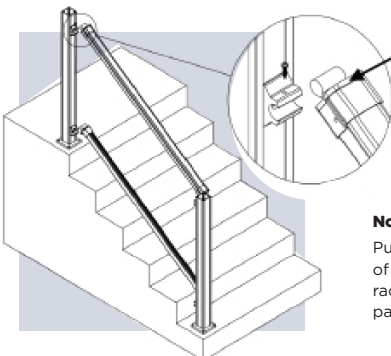

**Note**  
Push the top rail into the bottom of top stair bracket, screw top rackets to rail using 2 #8-3/4" pan head self-drilling screws.

## Step 3 Install pickets and spacers.

- 3.1 starting from either post, but skipping the first spacer, insert pickets into top and bottom rail and snap in spacers, one by one as shown below.

**Do not snap in spacers for the last 4 pickets. Insert last 4 pickets as a group and adjust the picket distance, then snap in the spacers.**

- 3.2 making sure that all pickets are plumb, install and spacers.

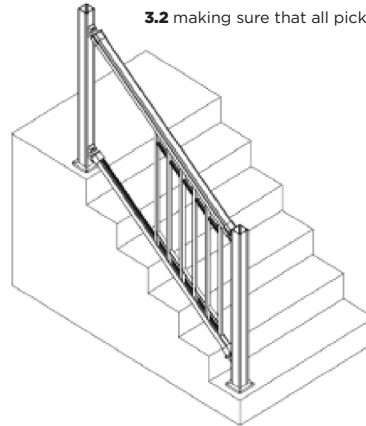

**Note**  
The size of the spacer for each end rail is different. (Special round labels will be used to identify the end spacer)  
Cut and spacers to fit the rails if necessary. To ensure equal packet spacing at each post, cut first and last spacers to equal lengths.

## Adjustable Bottom Rail Support

Adjustable bottom rail support consists of 3 parts, cut middle part to adjust height if necessary.

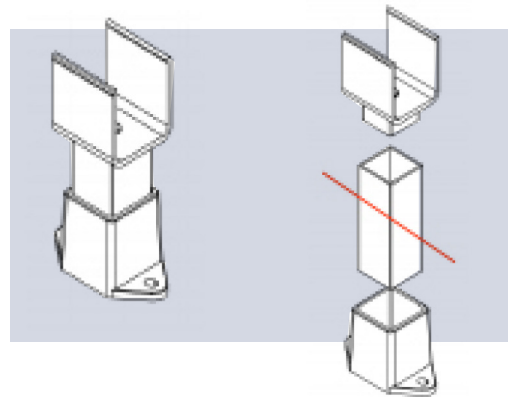

## Install Post Cap and Post Trim

Install post cap and post trim after all other components are installed.

Post cap locks into post, use of rubber mallet, or similar tool until tight.

Install the post trim as following:

Apply glue to holes of post trim (do not overflow)

Assemble 2 side of the post, trim, and pressed together for approximately 6 seconds.

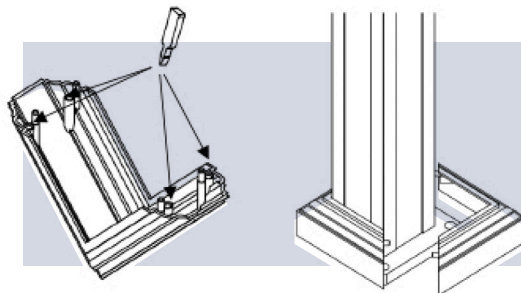

ICC-ES AC273 Compliant



EasternOrnamentalRailing.com

800-339-3362